

Model: JSMA-PBC04A3KB									
No.	Item	Symbol	Unit	Specification	No.	Item	Symbol	Unit	Specification
1	Drive	-	-	3 φ 220VAC	13	Rotor Inertia	J-M	kg-cm ²	0.73 ±10%
2	Cooling Method	-	-	Totally Enclosed	14	Rated Power Rate	Q-R	Kw/s	22.09
3	Exciting Method	-	-	Permanent Magnet	15	Resistance	Ra	Ω	3.15±10%/2 φ
4	Resolution	-	-	23 bit-INC	16	Inductance	L	mH	11±10% / 2 φ
5	Rated Output	P-R	W	400	17	Mech. Time Constant	Tm	ms	1.35±10%
6	Rated Torque	T-R	N-m	1.27	18	Elect. Time Constant	Te	ms	3.49±10%
7	Max. Torque	T-max	N-m	3.81	19	Insulation Class	-	-	Class F
8	Rated Speed	N-R	rpm	3000	20	Operation Temp.	T	°C	0~40
9	Rated Current	I-R	A	2.6	21	Operation Humd.	RH	%	<80
10	Max. Current	I-max	A	8.1	22	Storage Temp.	T	°C	-20°~60°
11	Torque Constant	Kt	N-m/A	0.47	23	Storage Humd.	RH	%	<80
12	Voltage constant	Ke	V/Krpm	32.78±10%	24	Weight	W	kgw	2.03

1	U	Red
2	V	White
3	W	Black
4	F/G	Grn/Yel

Motor Wiring

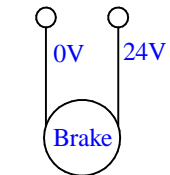

Brake Wiring

1	Vcc	White
2	GND	Black
3	-	-
4	-	-
5	SD+	Blue
6	SD-	Purple
7	-	-
8	-	-
9	FG	Shield

Encoder Wiring

- Note:
1. Motor to be IP67(excluding the shaft opening and connectors).
 2. Encoder shield wire to be grounded to the motor.

AC SERVO MOTOR
 Model: JSMA-PBC04A3KB
 Pr: 0.4 KW ; Nr: 3000_rpm
 Ir: 2.6 A , Tr: 1.27 N-m
 NO.
TECO ELECTRIC & MACHINERY CO., LTD.
 MADE IN TAIWAN

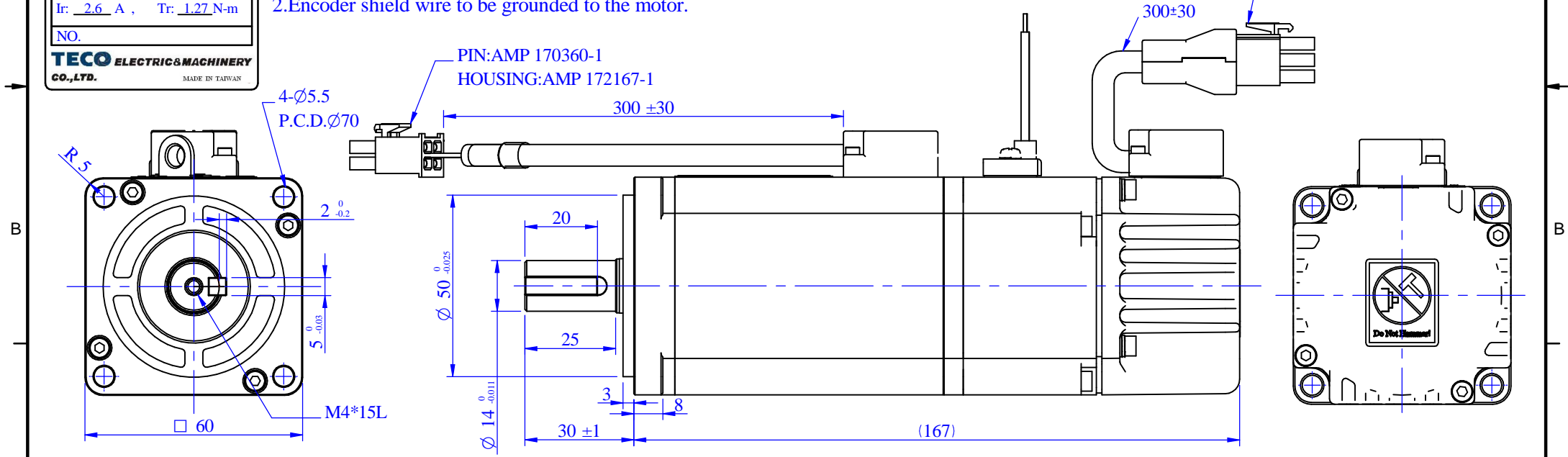

STANDARD TOLERANCE					APVD		SCALE	2/3	UNIT	mm	NAME	SERVO MOTOR OUTLINE DRAWING	
X	±0.5				CHKD		3RD .A.P	⊙	≡	TITLE	JSMA-PBC04A3KB		
.X	±0.2				CHKD						Leon 04-08-'16		
.XX	±0.05				DWN		TECO ELECTRO DEVICES CO., LTD.						
ANGLE	±30'												
MATERIAL		REV	DESCRIPTION	SIGNATURE	DATE	SIGNATURE	DATE						